

Product Information

DT595A Series 2-Wire Outdoor Station



DESCRIPTION

2-wire system audio outdoor station

DIMENSION

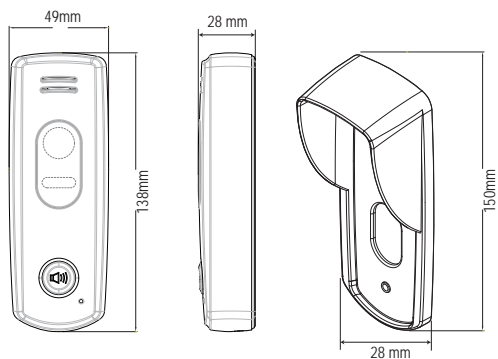

FEATURES

- ▶ Zinc alloy housing;
 - ▶ Compact design;
 - ▶ Surface wall mounting;
 - ▶ Strong waterproof;
 - ▶ Optical glass as the vidicon lens body;
 - ▶ IP55 protection rate;
-

1. Parts and Functions

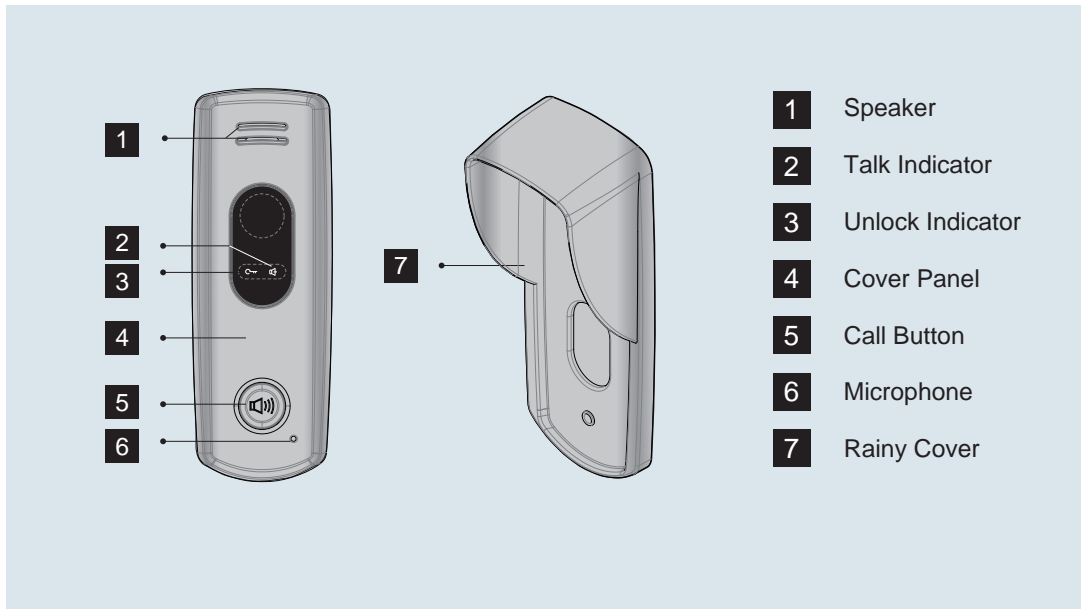

2. Door Station Mounting

Mounting with rainy cover only

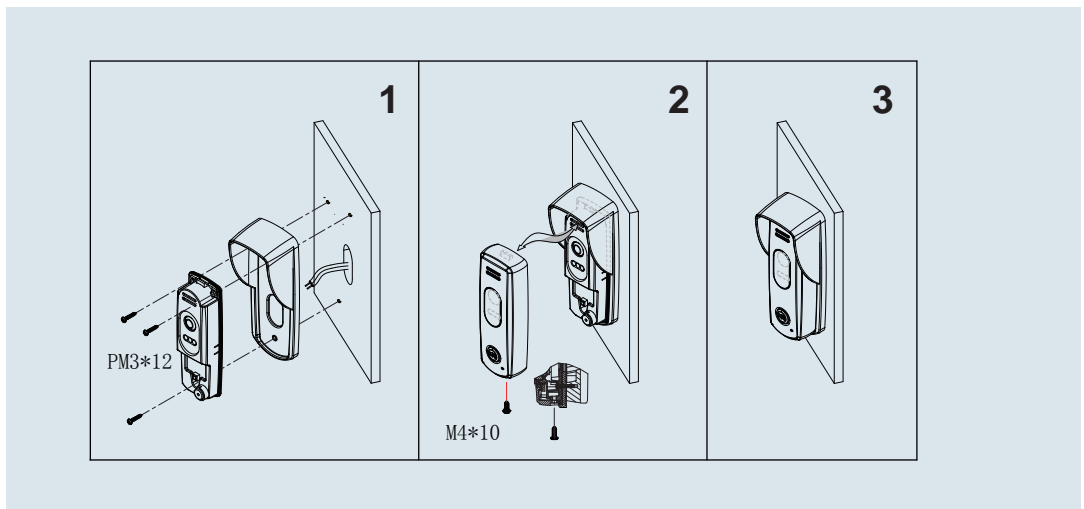

Mounting with rainy and 30° angle bracket

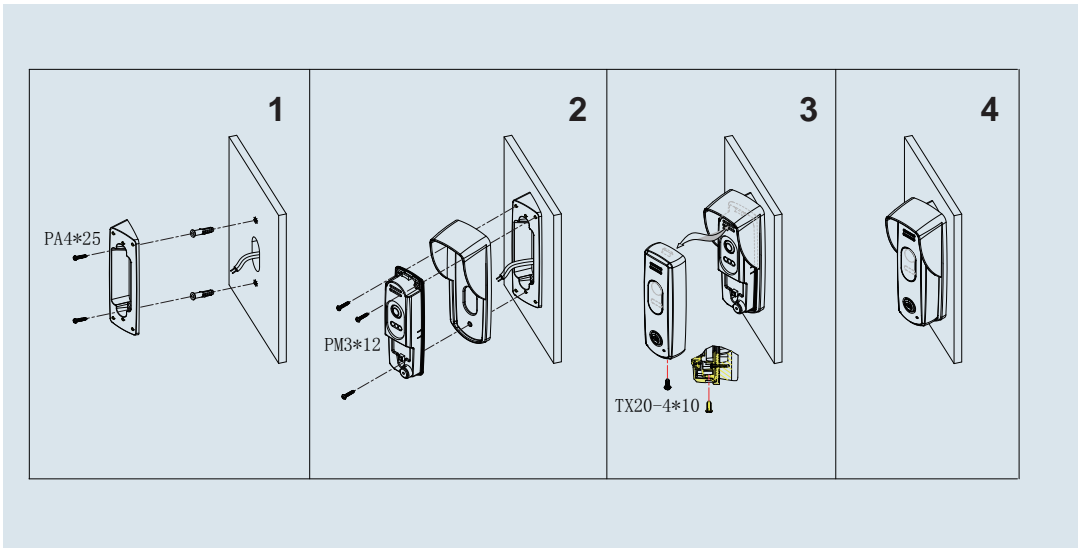

The location of outdoor station should keep away from snow,rain,and intensity light.

Accessory contents:

Accessories include a screwdriver T20, one M4X10 screw, two PA4X25 screws,three PA3x25 screws,three PM3x12 screws,and five screw stoppers Φ6X30.

Installation steps:

Installation height for door station usually is 145~160cm.

1. Use screws to fix the back panel and rainy cover to the wall after connect the cable correctly.
2. Attach the front panel to the back panel, then use the screw to fix it.

Note:1. the rainy cover is included in the package.

2. the 30° angle bracket is not included in the package, it should supply separately.

3. Specification

- * Power Supply : DC 24V (supplied by PS4-24V or PS5-24V);
- * Power Consumption: Standby 20mA; Working status 60mA;
- * Unlocking time: 1-9S, set by monitor;
- * Talk Time: 90S;
- * Lock Power supply: 12Vdc, 300mA(Internal Power);
- * Temperature: -10°C~+45°C;
- * Wiring: 2 wires (non-polarity);
- * Dimension: 150(H)×28(W)×40(D)mm

4. Ordering Information for Door Station

Model No.	Brief Description	Remark
DT595A	Audio door station	

5. Optional Accessories (Not included)

Item	Brief Description	Remark
AB595	30° angle adjust for DT595	should purchase seperately

5. Packing Information



Dimensions: 155 (H)×100 (W)×62 (D)mm
Gross Weight:



Carton: 415 (H)×360 (W)×265 (D)mm
Quantity: 32PCS